

DRUM RUNNER

Model 4550

Technical Data

Standard Features

- 800-lb Load Capacity
- Phenolic Wheels
- Hydraulic Cylinder Foot Pump
- Fully Counter-Balanced
- Handles Drums 29" - 53" Tall
- Sturdy Mild-Steel Construction
- 25" Maximum Lift Height, depending on drum height
- Steel-It®-Coated Frame

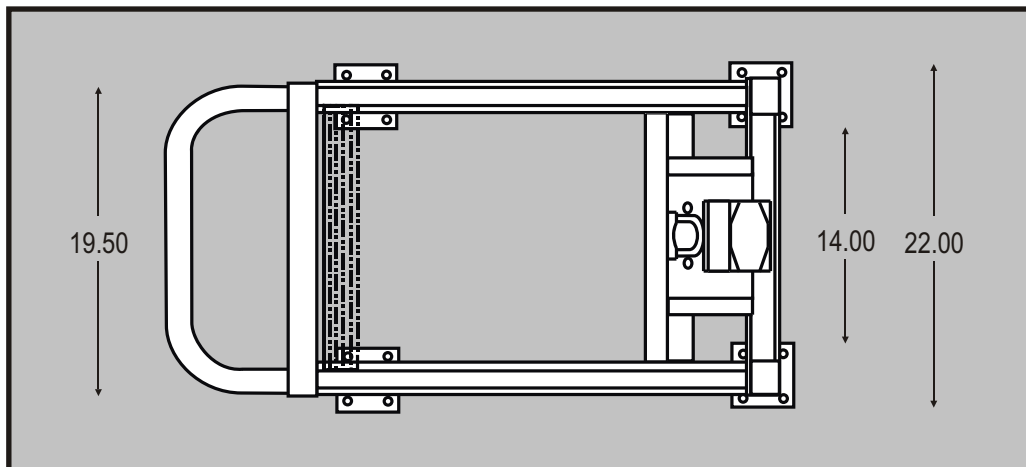
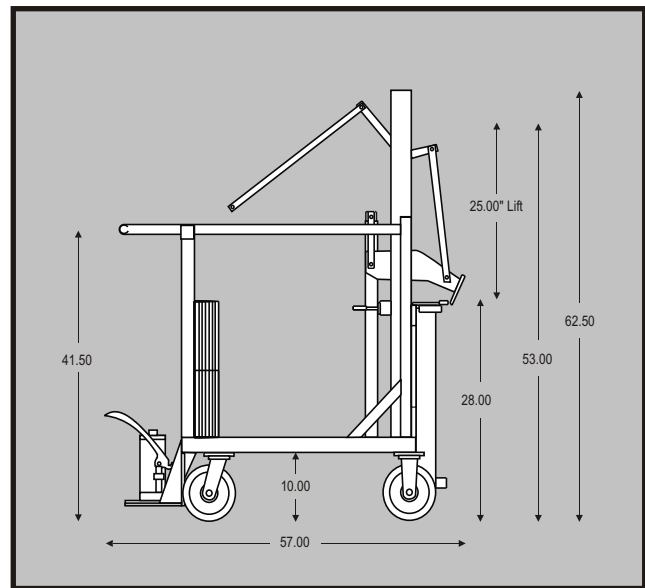

DRUM RUNNER

1-800-DRUM-RUN (1-800-378-6786)

617 West Center Street, Suite 126 Marion, Ohio 43302

www.drumrunner.com